

Application of Fuzzy Controller for Automatic Diagnosis of Rotor Broken Bars in Industrial Induction Motors

Cesar da Costa¹, Mauro Hugo Mathias²

¹*Department of Electrotechnical Engineering, IFSP-Federal Institute of Education, SP, Brazil*

²*Department of Mechanics, UNESP-Universidade Estadual Paulista Júlio de Mesquita Filho, Guaratinguetá, SP, Brazil.*

ABSTRACT

This paper presents an online trained Fuzzy logic system based on FPGA to fault detection of broken rotor bar for squirrel cage induction motor. Fuzzy logic approach may help to diagnose induction motor faults in remote site and transmit fault diagnosis (via GSM/GPRS cellular network technology) to maintenance office or a programmed cell phone. The motor current signal is analyzed through the FFT (Fast Fourier Transform) to detect the amplitudes and frequency components corresponding to different faults. These amplitudes and frequencies are applied to train a Fuzzy logic controller in simulation. Then the trained Fuzzy logic system is applied to detect the fault condition of induction motor in real time. This paper proposes the use of the proposed method for automatic diagnosis of broken bars in induction motors installed in remote locations.

Keywords: Fuzzy controller, machine monitoring; diagnostic, electrical machines, Field Programmed Gate Arrays.

INTRODUCTION

Induction motors with squirrel-cage type rotors are rugged, reliable, and cheap. Therefore, they are widely used in industrial and manufacturing processes. However, the electrical and mechanical failures of such motors often disrupt productivity and require maintenance, thus presenting special challenges in production. In the literature, rotor broken bar faults have been shown to account for a large proportion of industrial induction motor failures. It is important to note that even if the stator and rotor fault account makes up 38% of the all faults [1], it is very important to stop them in time because they can lead to total loss of the motor. A reliable system for diagnosis of such a fault should be able to detect the fault at an early stage, monitoring the motor condition online. In the context of diagnosis in induction motor, several methods can be used [2 - 3]. Over the past two decades artificial intelligent algorithms have been utilized for motor drives, fault detection, process control, etc. [4]. According to Jover Rodrigues et al, 2008, the smart methods are categorized to fuzzy logics, neural networks and genetic algorithm [5]. The fuzzy logic approach can be incorporated to the context of automatic diagnosis of fault in induction motor. A short time ago, applications of fuzzy logic for the diagnosis of faults in electrical machines has been emerged as solution for online diagnosis [6 - 7]. Early works on the detection of rotor broken bars using fuzzy logic are presented [8]. This application corresponds to squirrel cage induction motor. It suggests that rules should be known experimentally and with the help of an experienced technician.

Motor current signature analysis (MCSA) can be classified as the most promising fault-detection method for induction motor faults, stator short circuit and broken rotor bar problems in industrial induction motors. Commonly fault detection can be done either online or offline. A great number of researchers have reported success in using MCSA as fault detection method [9 - 10]. MCSA is

**Address for correspondence:*

cost036@hotmail.com

efficient due to its ability to sample the harmonics component in the stator current spectra that consists of induction motor fault information via Fast Fourier Transform (FFT). Spectral analysis of stator current method using the FFT is applied to the detection of broken rotor bars. However, in MCSA method the rotor and stator fault detection depends on the MCSA instrument, accuracy of extracted fault frequencies, experts' knowledge base, expert's knowledge decision, and the presence of an experienced on-site technician to drive tests [11]. Due to the distances involved in remote sites, this maintenance technique can increase time of shutdown motor and operational costs.

A Field Programmable Gate Array (FPGA) based controller portable monitor with an LCD display was reported [4]. However, all these studies still require an expert operator to interpret results in remote site in order to make reliable decisions

In this paper, fuzzy controller is used to make automatic decisions on motor condition with high accuracy, experts' knowledge base, and experts' knowledge decision. Unlike other researches, the diagnosis task proposed is to detect failure online, on the remote site, and transmit it via communication network, as soon as possible, to the central maintenance without the presence of a local experienced technician.

This paper is organized as follows. Section II gives a brief description of online condition monitoring by MCSA instrument. Section III presents the experimental feature extraction method. Section IV presents fuzzy controller method for diagnosis and decision. Section V presents the fuzzy controller embedded in hardware FPGA. Section VI presents experimental fuzzy controller system results. Finally, section VII presents the conclusion.

ONLINE MOTOR CONDITION MONITORING BY MCSA INSTRUMENT

A crucial point about motor current signature analysis (MCSA) is that it measures a current electrical signal that contains current components that are a direct by-product of unique rotating flux components caused by faults such as broken rotor bars, air gap eccentricity, and shortened turns in low voltage stator windings. MCSA method can detect these problems at an early stage, thus avoid secondary damage, and complete failure of the motor [11]. A typical online motor condition monitoring system consists of

- Sensor: measures the current quantities of the device and converts them into a voltage response in time domain. Several kinds of sensors are used: current sensor clamp, Hall Effect sensor, flux sensor.
- Data acquisition: samples, amplifies and converts analog sensor signal into digital values.
- Processor: processes digital signal of current in time domain and transforms it into frequency domain through FFT algorithm. The current spectral analysis decomposes the signal into its frequency components; in this case, they are called harmonics.
- Display: Shows the spectrum of frequency and its harmonics.

The fault diagnosis by MCSA method need an experienced technician to extract information from the current spectrum display, such as amplitudes and frequencies, and decides whether the machine's operating state is faulty or healthy [9 – 10].

FEATURE EXTRACTION METHOD

If there is only a forward rotating field at slip frequency relative to the rotor, the cage winding is symmetrical. Where rotor asymmetry occurs, then there will be a resultant backward rotating field at slip frequency relative to the forward rotating rotor. The result of this is that, relative to the stationary stator winding, this backward rotating field at slip frequency relative to the rotor induces a voltage and current in the stator winding at frequency given by [12 -15].

$$f_{bb} = (1 - 2s) f_0 \text{ Hz} \quad (1)$$

This is referred to as a twice slip frequency sideband due to broken rotor bars; where s is the motor slip and f_0 is the frequency of the power grid to which the motor is connected.

There is therefore a cyclic variation of stator current that causes a torque pulsation at twice slip frequency ($2sf_0$) and a corresponding speed oscillation that is also a function of the drive inertia. This speed oscillation can reduce the magnitude of the $(1 - 2s) f_0$ sideband, but an upper sideband current component at $(1 + 2s) f_0$ is induced in the stator winding due to the rotor oscillation. This upper sideband is also enhanced by the third harmonic of the flux. Broken rotor bars therefore result in current components being induced in the stator winding at frequencies given by:

$$f_{bb} = (1 \pm 2s) f_0 \text{ Hz} \quad (2)$$

Experimental Setup

To demonstrate the application of the feature extraction method, an analysis of different signals collected from rotor broken bars was performed, which were forced in the laboratory by opening the motor and drilling holes in different bars (Figure 1).

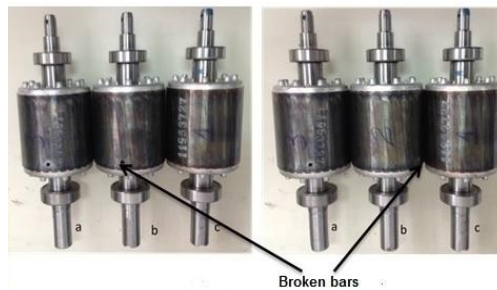

Figure1. Rotors with broken bars forced in laboratory

For validating the feature extraction method that uses a MCSA based instrument, several tests were performed with a 4-pole, 3-phase, 60 Hz, 1.5 kW, 220/380 V (rated voltage), 1750 rpm (rated speed), and 28-rotor-bar induction motor. Figure 2 shows the experimental setup. The load was a 2 kW DC machine with a rated speed of 1800 rpm.



Figure2. View of experimental setup

Spectrum of Stator Current

To verify the efficiency of the feature extraction method, we carried out several tests under different loads for healthy rotors and faulty rotors with broken bars. In each case, the stator current was transformed into frequency domain and analyzed by the MCSA based instrument. Then, the amplitudes of the two fault frequency components f_{bb1} (left frequency broken bars) and f_{bb2} (right

frequency broken bars) are analyzed and extracted. The results are summarized and shown. The sampling rate defined was 2 kHz, 4000 samples and frequency resolution equal to 0.5 Hz. Then, the fault frequency components f_{bb_l} (left frequency broken bars) equal to 56 Hz $((1 - 2s)f_0)$ and f_{bb_r} (right frequency broken bars) equal to 64 Hz $((1 + 2s)f_0)$ are analyzed and extracted. Fig. 3 shows spectrum of stator current for a healthy motor at 95% of rated load and motor speed is equal to 1,738 rpm. The amplitude of left frequency broken bars component (Af_{bb_l}) is 55 dB lower than the amplitude of the grid frequency (60 Hz) and amplitude of right frequency broken bar component Af_{bb_r} is 70 dB lower.

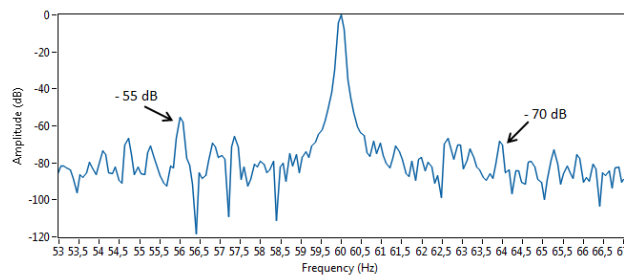

Figure3. Current spectrum: Loaded healthy motor

Figure 4 shows the spectrum of stator current for one broken bar at 90% of the rated load, and motor speed is equal to 1745 rpm. The fault frequency component f_{bb_l} (left frequency broken bars) equal to 56.33 Hz $((1 - 2s)f_0)$ and f_{bb_r} (right frequency broken bars) equal to 63.67 Hz $((1 + 2s)f_0)$ are analyzed and extracted. The amplitude Af_{bb_l} is 40 dB lower than the amplitude of the grid frequency and the amplitude frequency of left broken bars component (Af_{bb_r}) is 45 dB lower.

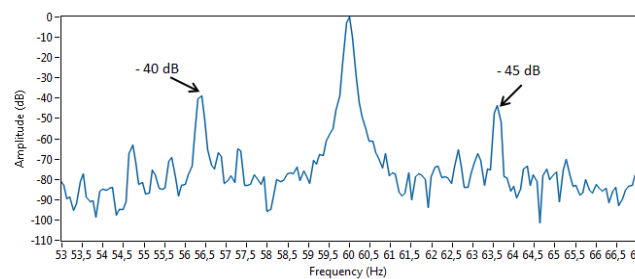

Figure4. Current spectrum: Loaded motor with one broken bar.

Figure 5 shows spectrum of stator current for two broken bars at 85% of rated load and motor speed equal to 1746 rpm. The fault frequency components f_{bb_l} (left frequency broken bars) equal to 56.40 Hz $((1 - 2s)f_0)$ and f_{bb_r} (right frequency broken bars) equal to 63.60 Hz $((1 + 2s)f_0)$ are analyzed and extracted. The amplitude Af_{bb_l} is 35 dB lower than the amplitude of the grid frequency and the amplitude Af_{bb_r} is 40 dB lower.

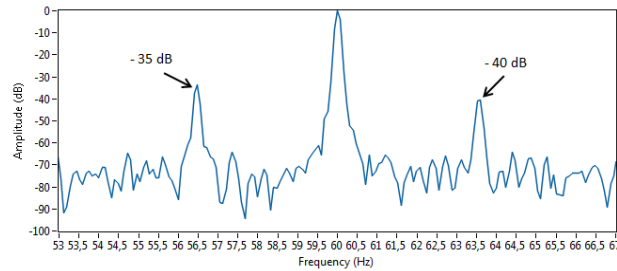

Figure 5. Current spectrum: loaded motor with two broken bars.

FUZZY CONTROLLER METHOD FOR DIAGNOSIS AND DECISION

Fuzzy logic is a form of many valued logics that deal with approximate, rather than fixed and exact reasoning. Compared to traditional binary logic (where variables may take on true or false values), fuzzy logic variables may have a truth-value that ranges in degree from 0 to 1. Fuzzy logic has been extended to handle the concept of partial truth, where the truth-value may range from completely true to completely false. Furthermore, when linguist variables are used, these degrees may be managed by specific functions. The membership functions (inputs and outputs) variable such as *age* may have a value such as *young* or its antonym *old*. However, the great utility of linguistic variables is that they can be modified via linguistic hedges applied to primary terms. These linguistic can be associated with certain functions. The fuzzification (Mandani method) is the mapping of the domain of real numbers (discrete in general) for the fuzzy domain, defined by relevancy functions to the input variables [16 – 20]. It is a type of preprocessing of categories or classes of input signals, thereby reducing the number of values to be processed.

Table 1 summarizes the behavior of induction motor parameters, obtained in the fault diagnosis by MCSA based instrument, which are used as variables of the fuzzy controller method.

Table 1. Behavior of induction motors parameters

Diagnosis	Amplitude(dB) Af_{bb_l}	Amplitude (dB) Af_{bb_r}	MotorSpeed(rpm)
Health Motor	-100 to -55 (Normal)	-100 to -55(Normal)	1776
1 – 2 Broken bar	-50 to -35 (Increase)	-50 to -35 (Increase)	1745
≥ 3 bar	-30 to 0 (Increase)	-30 to 0 (Increase)	1746

The fuzzy controller system suggested the implementation of the Fuzzy Logic method as shown in Figure 6, through block diagram. The first step is acquiring data, which is, collecting motor parameters that may be relevant in the search for information on the motor status. Herein, in particular, stator current and motor shaft speed will be measured using a current sensor and a motor shaft rotation sensor.

After measuring the data, the current signal is pre-processed, that is, by means of the FFT; the signal frequency spectrum is obtained to show frequencies of side failure of broken bars $(1 \pm 2s)f_0$.

After obtaining the two frequencies components f_{bb_l} (left side broken bars frequency) and f_{bb_r} (right side broken bars frequency), their magnitudes Af_{bb_l} and Af_{bb_r} will be extracted by applications of

software programs developed, using various general-purpose programming languages such as LabVIEW. The third step, called fuzzy controller, refers to the use of Fuzzy Inference System (FIS) techniques, implemented in an FPGA that provides the induction motor condition automatically, in real time, without requiring a display for analysis and a specialist technician for diagnosis and decision.

The Fuzzy Inference System

The input variables are the magnitudes of the right side failure frequency (Af_{bb_r}), left side failure frequency (Af_{bb_l}), and motor shaft rotation (speed). The reasons for these choices were presented in Table 1 (Behavior of induction motors parameters). The output variables are *Healthy*, *Defect*, and *Severe Defect*. The purpose of the system is to provide a diagnosis of the Motor Condition (MC); therefore, the output variables refer back to one of the possible states of the motor. Fuzzy inference rules operate in the affirmative mode. Summarizing, this system is composed of three input variables, ten rules, and one output variable.

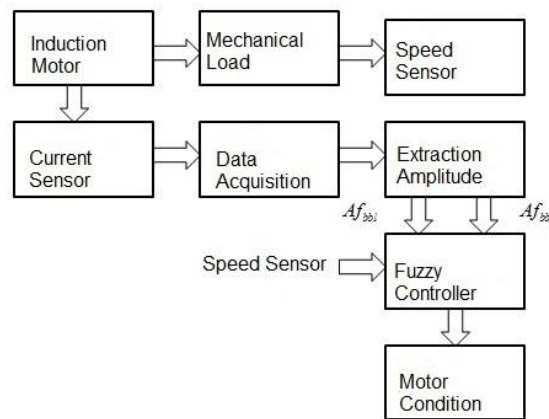

Figure6. Block diagram of fuzzy controller method

Fuzzification (Membership Function)

The input variables Af_{bb_l} and Af_{bb_r} , in real numbers domain, have their values expressed in dB and are normalized from 0 to 1, 0 being equivalent to -100 dB and 1 being equivalent to 0 dB. The *speed* variable in the real numbers domain has its values normalized from 0 to 1, 0 being equivalent to 1740 rpm and 1 being equivalent to 1790 rpm.

For each variable, three relevancy functions are stipulated, denominated *Small*, *Medium*, and *Big*. The *Medium* function refers to input variables nominal values, where values 0.50 (-50 dB) to 0.65 (-35 dB) indicate the motor value with one to two broken bars. The *Small* function outlines values considered for a *healthy* motor, where values equal to or smaller than 0.45 (-55 dB) points to a maximum relevancy value. Similarly, the *Big* function depicts the motor values with defects of three or more broken bars, where values equal to or greater than 0.70 (-30 dB) points to a maximum relevancy value. The following characteristics are common to the three variables: Magnitude of left side failure frequency (Af_{bb_l}), Magnitude of right side failure frequency (Af_{bb_r}), and motor speed.

Base of Rules

An important part of a failure diagnosis system by Fuzzy Logic is constructing the base of rules [17 – 21]. The knowledge acquisition begins with the transfer of Human’s knowledge of the motor conditions to the rule base. Based on the fault diagnosis by MCSA method (experimental setup), a set of 10 rules was prepared, which comprises the Fuzzy inference system. For the input variables, previously defined letters S (Small), M (Medium), and B (Big) were used. As Motor Condition (MC) *Healthy*, *Defect* and *Severe Defect* were used.

Defuzzification

In defuzzification, the output linguistic variable value inferred by the Fuzzy rules will be translated into a discrete value. The objective is to obtain a single discrete numerical value that best represents the inferred Fuzzy values of the output linguistic variable, i.e., distribution possibilities [19 – 20]. Thus, defuzzification is an inverse transformation that translates the Fuzzy domain output into discrete domain. Table 2 describes the output range for these variables.

Table2. Range of output variables.

Range	Rotor Condition	Number Broken Bars
$0 \leq output \leq 0.47$	Health	0
$0.5 \leq output \leq 0.7$	Defect	1 - 2
$0.75 \leq output \leq 1$	Severe Defect	3 or more

EMBEDDED SYSTEM IN HARDWARE FPGA

The fuzzy controller/DAQ (Data acquisition systems) hardware model was subsequently synthesized and implemented in a Field Programmable Gate Array (FPGA) chip [6], [4], [21 – 23]. The embedded system used in the testing bench is based on a controller/DAQ, NI sbRIO 9602 from National Instruments. The controller architecture includes a floating point processor running at 400 MHz, real-time operating system (RTOS), high-performance FPGA Xilinx, interface 10\100 Base T Ethernet. Fig. 7 shows the controller architecture NI sbRIO-9602.



Figure7. NI sbRIO Hardware with FPGA

The sbRIO-96xx devices are programmed using the NI LabVIEW graphical programming language. The real-time processor runs the LabVIEW Real-Time Module on the Wind River VxWorks real-time operating system (RTOS) for extreme reliability and determinism. It can integrate C code libraries within LabVIEW Real-Time.

NI sbRIO 9602 is programmed using (i) PC LabVIEW; (ii) LabVIEW Real-Time; and (iii) LabVIEW FPGA. It runs applications (deterministically) developed with the LabVIEW Real-Time software and the FPGA executes simultaneously applications developed with the LabVIEW FPGA software.

The development of the fuzzy controller diagnosis system warranted the development of three (VIs) programs. Two programs were developed in LabVIEW Real-Time and LabVIEW FPGA, running directly on CompactRIO. The other program was developed in LabVIEW PC, running on a personal computer (Host PC). The program (VI) in the host PC communicates with the LabVIEW Real-Time program through shared variables via the TCP/IP protocol. For data transfer between the LabVIEW FPGA and LabVIEW Real-Time programs, I/O variables are used.

Gsm/Gprs Cellular Network

General Packet Radio Services (GPRS) is a packet -based wireless communication service that promises data rates from 56 up to 114 Kbps and continuous connection to the Internet for mobile phone and computer users. GPRS is based on Global System for Mobile (GSM) communication and complements existing services such as circuit-switched cellular phone connections and Short Message Service (SMS). GSM can be applied in tele-monitoring applications, where high mobility and low

cost are necessary [24]. The Fuzzy controller via GSM \ GPRS cellular network consists of four elements: NI sbRIO-9602 card (Fuzzy Controller/DAQ), application interface (communication software), communication base (Remote GSM provider) and GSM Modem (Netbiter WS200). The Fuzzy controller monitors and makes the diagnosis of the induction motor conditions (healthy, defect, severe defect) on the remote site, and transmits the overall result, via communication network, to the central computer maintenance or a programmed cell phone. Fig.8 illustrates the GSM/GPRS cellular network proposed. A Gateway (Netbiter WS200) with an inbuilt Webserver for remote monitoring of equipment on a Local area network. Alarm and status information can be sent by SMS or email via GSM/GPRS. The Fuzzy controller/DAQ (sbRIO-9602) monitors and makes the detection of the induction motor faults automatic on the remote sites, and transmits the overall result, via Netbiter WS 200 radio MODEM, to the computer central maintenance or a programmed cell phone. The Netbiter WS 200 series gateway is a perfect solution to monitor and control devices that are located on the same site as the monitoring station.

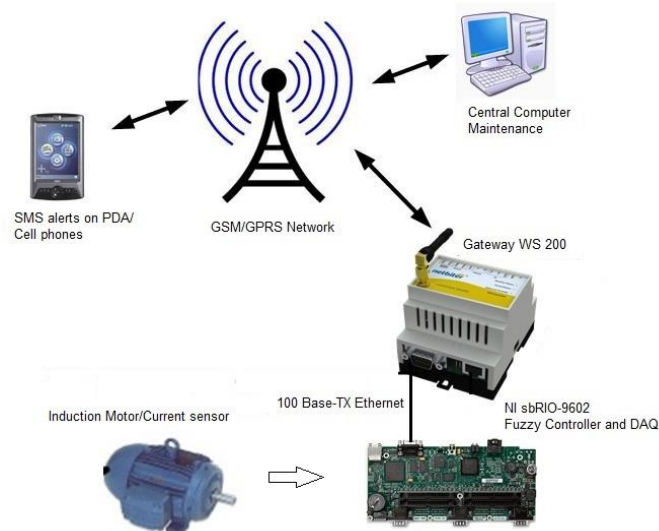

Figure8. GSM/GPRS network communica

Experimental Fuzzy Controller System Results

To verify the efficiency of the fuzzy controller system, several tests were performed via GSM network. These tests were performed under different loads and motor conditions: Healthy rotor, one broken bar and two broken bars. Table 3 presents the results of a healthy motor diagnosis (value normalized and real) with low load, half load and full load. The simulation in software MATLAB the overview of all 10 implemented rules and the result with a single discrete numeric value normalized equal to 0.22, which indicates the rotor Healthy condition (Table 2 - Range of output variables).

Table3. Diagnostic results for Healthy.

Load	$A_{f_{bbl}}$	$A_{f_{bbr}}$	Motor Speed	Motor Condition
Low	0.46 -55.54 dB	0.30 -70 dB	0.50 1769 rpm	0.22 Healthy
Half	0.46 -54.55 dB	0.30 -70 dB	0.50 1752 rpm	0.22 Healthy
Full	0.46 -54.11 dB	0.30 -58.91 dB	0.50 1769 rpm	0.22 Healthy

Table 4 shows the results of a defect motor diagnosis (1 broken bar) with low load, half load and full load. The simulation in software MATLAB the overview of all 10 implemented rules and the result with a single discrete numeric value normalized equal to 0.6, which indicates the rotor condition Defect 1 broken bar (Table 2 - Range of output variables).

Table4. Diagnostic results of 1broken bar

Load	Af_{bbl}	Af_{bbr}	Motor Speed	Motor Condition
Low	0.60 -40.37 dB	0.57 -43.50 dB	0.20 1745 rpm	0.6 Defect
Half	0.61 -40.50 dB	0.57 -43.64 dB	0.45 1760 rpm	0.6 Defect
Full	0.55 -44.73 dB	0.55 -45.29 dB	0.60 1774 rpm	0.6 Defect

Table 5 shows the results of a Defect motor diagnosis (2 broken bars) with low load, half load, and full load. The simulation in software MATLAB the overview of all 10 implemented rules and the result with a single discrete numeric value normalized, equal to 0.6, which indicates the rotor condition Defect 2 broken bars (Table 2 - Range of output variables).

Table5. Diagnostic results of 2 broken bars.

Load	Af_{bbl}	Af_{bbr}	Motor Speed	Motor Condition
Low	0.63 -37.34 dB	0.60 -40.45 dB	0.20 1746 rpm	0.6 Defect
Half	0.65 -35.50 dB	0.57 -42.84 dB	0.45 1760 rpm	0.6 Defect
Full	0.59 -41.30 dB	0.59 -41.25 dB	0.60 1776 rpm	0.6 Defect

CONCLUSION

In this paper, a real time condition-monitoring device based on fuzzy controller was developed and tested. The target controller based on FPGA and GSM network is capable of measuring non-invasive sensor signals and is capable of analyzing them for extraction of rotor problems in induction motors installed in remote sites.

A diagnosis method using fuzzy logic to determine the state condition of induction motors was presented. In order to make an efficient diagnosis, frequency amplitudes (left and right broken bars) components of the spectrum stator current and speed motor are input to the fuzzy controller system, which converts it into linguistic variables fuzzy subsets and their corresponding membership functions. The output of this system represents the motor conditions.

The fuzzy controller system monitors and makes the diagnosis of induction motors conditions on the remote site and transmits the overall results, via GSM network, to the central computer of maintenance officer or a programmed cell phone. The results obtained with this system are good and capable of detecting rotor problems in industrial induction motor installed in remote sites.

REFERENCES

- [1] Thomson W. T, Fenger M. (2001). Current signature analysis to detect induction motor faults. IEEE Trans. Ind. Appl. 7: 26–34.
- [2] Pu S, Zheng C, Yuriy V, Zoubir Z (2013). A new diagnosis of broken rotor bar fault extent in three phase squirrel cage induction motor. Mech. Sys. Signal Process. 42:388-403.

- [3] Nandi S, Toliyat HA, Xiaodong L. (2005). Condition monitoring and fault diagnosis of electrical motors. *IEEE Trans. on Energy Conversion*, 20:719-729.
- [4] Yepez EC, Rodriguez MV, Troncoso RJR, Perez AG, Rios RAO, Vidales HM, Salas RA (2012). FPGA- based entropy neural processor for on line detection of multiple combined faults on induction motors. *Mech. Sys. Signal Process.* 30:123-130.
- [5] Jover Rodriguez PV, Arkkio A (2008). Detection of stator winding fault in induction motor using fuzzy logic. *Applied Soft Computing* 8:1112-1120.
- [6] Saghafinia A, Kahourzade S, Mahmoudi A, Hew WP, Uddin MN(2012). On line trained fuzzy logic and adaptive continuous wavelet transform based high precision fault detection of IM with broken rotor bars. *Industry Applications Society Annual Meeting (IAS), 2012 IEEE, Las Vegas*, pp. 1 - 8.
- [7] Boukaka S, Teiar H, Chaoui H, Sicard P (2014). FPGA implementation of an adaptive fuzzy logic controller for PMSM, *Power Electronics, Machines and Drives (PEMD 2014). 7th IET International Conference on, Manchester*, pp. 1-6.
- [8] Laala W, Guedidi S, Zouzou S (2011). Novel approach for Diagnosis and detection of broken bar in induction motor at low slip using fuzzy logic. *Diagnostic for Electronic Machines, Power Electronics & Drives (SDEMPED), 2011 IEEE International Symposium on*, pp. 511-516.
- [9] Guedidi S, Zouzou SE, Laala W, Sahraoui M, Yahia K (2011). Broken bar fault diagnosis of induction motors using MCSA and neural network," in *Diagnostics for Electric Machines. Power Electronics & Drives (SDEMPED), 2011 IEEE International Symposium on*, pp. 632-637.
- [10] Da Silva Gazzana D, Pereira L A, Fernandes D (2010). An automated system for incipient fault detection and diagnosis in induction motors based on MCSA. *Industrial Technology (ICIT), 2010 IEEE International Conference on*, pp. 1227-1232.
- [11] Bakhri S, Ertugrul N, Soong WL, Al-Sarawi S (2007). Investigation and development of a real-time on-site condition monitoring system for induction motors. *Australasian Universities Power Engineering Conference, Australia*, pp. 1-6.
- [12] Bin GF, Gao JJ, Li XJ, Dhillon BS (2012). Early fault diagnosis of rotating machinery based on wavelet packets – Empirical mode decomposition feature extraction and neural network. *Mech. Sys. Signal Process.* 27:696-711.
- [13] Georgoulas G, Tsoumas IP, Daviu JAA, Alarcon VC (2014). Automatic pattern identification based on the complex empirical mode decomposition of the startup current for diagnosis of rotor asymmetries in asynchronous machines. *IEEE Trans. Ind. Electron.* 61:4937-4946.
- [14] Kaikaa MY, Hadjami M (2014). Effects of the simultaneous of static eccentricity and broken rotor bars on the stator current of induction machine. *IEEE Trans. Ind. Electron.* 61:2452-2463.
- [15] Kim YH, Youn YW, Hwang DH, Sun JH, Kang DS (2013). High-resolution parameter estimation method to identify broken rotor bar faults in induction motors. *IEEE Trans. Ind. Electron.* 60:4103-4117.
- [16] Silvert A, Betin F, Moghadasian M, Yazidi A, Capolini GA, (2012). Position control of six-phase induction motor using fuzzy logic: application to electric power steering. *Electrical Machines (ICEM), 2012 XXth International Conference on Marseille*, pp. 1055-1061.
- [17] Lin FJ, Hung YC, Hwang JC, Tsai MT (2013). Fault-tolerant control of a six-phase motor drive system using a Takagi-Sugeno-Kang type fuzzy neural networks with asymmetric membership functions. *IEEE Trans.s Power Electron.* 28:3557-3572.

- [18] Maslak W, Butkiewicz BS (2013). Autonomous vehicle with fuzzy control. Signal Processing Symposium (SPS), IEEE 2013, Serock, pp. 1- 6.
- [19] Azgomi HF., Joshtan P, Poshtan M (2013). Experimental validation on stator fault detection via fuzzy logic. 3rd International Conference on Electric Power and Energy Conversion Systems (EPECS), IEEE 2013, Istanbul pp. 1- 6.
- [20] Rodrigues PV, Arkkio A (2008). Detection of stator winding fault in induction motor using fuzzy logic. Appl. Soft Comput. 8:1112-1120.
- [21] Medina LMC, Troncoso RJR, Cabal EY, Magdaleno JJR, Almaraz JRM (2010). FPGA- based multiple channel vibration analyser for industrial applications in induction motor failure detection. IEEE Trans. Instrum. Measure. 15:63- 72.
- [22] Gdaim S, Mtibaa A, Mimouri M (2014). Design and experimental implementation of DTC of induction machine based on fuzzy logic control on FPGA, Fuzzy Systems. IEEE Trans. 99:1.
- [23] Da Costa C, Mathias M H, Ramos P, Girão P (2010). A new approach for real time fault diagnosis in induction motors based on vibration measurement. Instrumentation and Measurements Technology Conference (I2MTC), 2010 IEEE, Austin, pp.1164 – 1168.
- [24] Ahmed E, Kohno R (2013). Medical reliable network using concatenated channel codes through GSM network, Engineering in Medicine and Biology Society (EMBC). 35th Annual Int. Conf. IEEE, Osaka, pp. 4755-4758.

AUTHORS' BIOGRAPHY



Cesar da Costa was born in Rio de Janeiro, Brasil.

He received the B.Sc. degree in electronic and electrical engineering from the CEFET-RJ, Federal Center of Technological Education Celso Suckow da Fonseca and Nuno Lisboa University in 1975 and 1980, respectively. He received the M.S. degree in mechanical engineering from Taubate University, São Paulo, Brazil and the Ph.D. degree in Mechanical engineering from UNESP-Universidade Estadual Paulista Júlio de Mesquita Filho, Guaratinguetá, SP, Brazil in 2005 and 2011, respectively. . He did Sandwich doctoral stage, PDEE - CAPES, in the IST - Instituto Superior Técnico, Lisbon, Portugal, in 2009. He is currently post doctorate and professor of automation and control engineering in the IFSP-Federal Institute of Education, SP, Brazil. His research interests include Fuzzy controller, machine monitoring, diagnostic, electrical machines and FPGA.



Mauro Hugo Mathias was born in Guaratingueta, SP, Brasil.

He received the B.Sc. and M.Sc degree in mechanical engineering from the UNESP-Universidade Estadual Paulista Júlio de Mesquita Filho, Guaratinguetá, SP, Brazil in 1982 and 1989, respectively. He received the Ph.D. degree in Mechanical engineering from Campinas State University, Campinas, SP, Brazil in 1998. He is currently associate professor of UNESP- Universidade Estadual Paulista Julio de Mesquita Filho, vibration workgroup member of the Brazilian Association of Non-Destructive Testing and Inspection, professional SNQC / END18538. He has experience in Mechanical Engineering with emphasis on Dynamics of Rigid Bodies, elastics and Plastics, acting on the following topics: signal processing, modeling of dynamic systems, predictive maintenance, vibration analysis and dynamic systems. Reviewer of the Journal Mechanical System and Signal Processing since 2010.